



Songs On Trial-09-12-2024



Achy Breaky Heart	2
City of New Orleans	4
Cool-For-Cats	5
Dancing in the Dark	7
Don't Think Twice	8
Don't Stop Believing	9
Doo Wah Diddy	10
Duelling Ukes	11
Fat Bottomed Girls	13
I can't find my way home	14
Maybe Tomorrow	15
Me and Julio down by the schoolyard	16
Mrs Robinson	17
Oom Pah Pah	18
Pretty Flamingo	19
River deep, mountain high	20
Senses working overtime	21
Sam Hall	22
We Will Rock You	23
Wurzels Medley	24

Achy Breaky Heart

key:F, artist: Billy Ray Cyrus writer: Don Von Tress

<https://www.youtube.com/watch?v=byQIPdHMPjc0>

Thanks to John Arkinstall

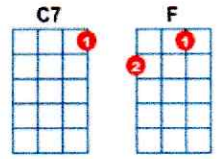

[F] [F] [F] [C7]

[F] Well you can tell the world you never was my girl
You can burn my clothes when I am [C7] gone
Or you can tell your friends just what a fool I've been
And laugh and joke about me on the [F] phone

You can tell my arms go back'n to the farm
Or you can tell my feet to hit the [C7] floor
Or you can tell my lips to tell my fingertips
They won't be reaching out for you no [F] more

[F] Don't tell my heart my achy breaky heart
I just don't think he'd under-[C7]stand
And if you tell my heart my achy breaky heart
He might blow up and kill this [F] man [F] oooo [F] ooooo

[F] Well you can tell the world you never was my girl
You can burn my clothes when I am [C7] gone
[C7] Or you can tell your friends just what a fool I've been
And laugh and joke about me on the [F] phone

You can tell your ma I moved to Arkansas
Or you can tell your dog to bite my [C7] leg
Or tell your brother Cliff whose fist can tell my lip
He never really liked me any-[F]way

Or tell your aunt Louise tell anything you please
Myself already knows I'm not o [C7] k
Or you can tell my eye to watch out for my mind
It might be walkin' out on me to-[F]day

[F] Don't tell my heart my achy breaky heart
I just don't think he'd under-[C7]stand
And if you tell my heart my achy breaky heart
He might blow up and kill this [F] man [F] oooo [F] ooooo

[F] Don't tell my heart my achy breaky heart
I just don't think he'd under-[C7]stand
And if you tell my heart my achy breaky heart
He might blow up and kill this [F] man [F] oooo [F] ooooo

Chorus a cappella:

Don't tell my heart my achy breaky heart
I just don't think he'd understand
And if you tell my heart my achy breaky heart
He might blow up and kill this man [F] oooo [F] ooooo

[F] [F] [F] [C7].
[C7] [C7] [C7] [F]*

City of New Orleans [G]

key:G, artist:Steve Goodman writer:Steve Goodman

[G] Riding on the [D] City of New [G] Orleans,
[Em] Illinois Central [C] Monday morning [G] rail [D]
[G] There's fifteen cars and [D] fifteen restless [G] riders,
[Em] Three conductors and [D] twenty-five sacks of [G] mail.
[Em] Out on the southbound odyssey and the [Bm] train pulls out at Kankakee
[D] Rolls past the houses, farms and [A] fields.
[Em] Passin' towns that have no names, [Bm] and freight yards full of old black men
And the [D] graveyards of the [D7] rusted automo-[G]biles [G7]

Singing [C] Good morning [D] America how [G] are you?
[Em] And don't you know me [C] I'm your native [G] son [D]
I'm just the [G] train they call The [D] City of New [G] Orleans,
I'll be [F] gone five [C] hundred [D] miles when the day is [G]
done. [D]

I was dealin' [G] cards with the [D] old men in the [G] club car.
[Em] And it's penny a point there ain't [C] nobody keepin' [G]
score. [D]
[G] Pass that paper [D] bag that holds that [G] bottle
[Em] You can feel the wheels [D] rumblin' beneath the [G] floor.

The [Em] sons of pullman porters and the [Bm] sons of engineers
Ride their [D] daddy's magic carpet made of [A] steel.
[Em] Mothers with their babes asleep, go [Bm] rockin' to the gentle beat
And the [D] rhythm of the [D7] rails is all they [G] feel. [G7]

Singing [C] Good morning [D] America how [G] are you?
[Em] And don't you know me [C] I'm your native [G] son [D]
I'm just the [G] train they call The [D] City of New [G] Orleans,
I'll be [F] gone five [C] hundred [D] miles when the day is [G] done. [D]

[G] It's night-time on The [D] City of New [G] Orleans,
[Em] And we're changing cars in [C] Memphis, Tennes-[G]-see. [D]
[G] Half way home, [D] we'll be there by [G] morning
Through the [Em] Mississippi darkness [D] rolling to the [G] sea.

[Em] All the towns and people seem to [Bm] fade into a bad dream
And the [D] old steel rails still ain't heard the [A] news.
The con-[Em]-ductor sings that song again, the [Bm] passengers will please refrain
[D] This train has got the [D7] disappearing railroad [G] blues. [G7]

Singing [C] Good morning [D] America how [G] are you?
[Em] And don't you know me [C] I'm your native [G] son [D]
I'm just the [G] train they call The [D] City of New [G] Orleans,
I'll be [F] gone five [C] hundred [D] miles when the day is [G] done. [G7]
(Repeat chorus then) [C] [D] [G]

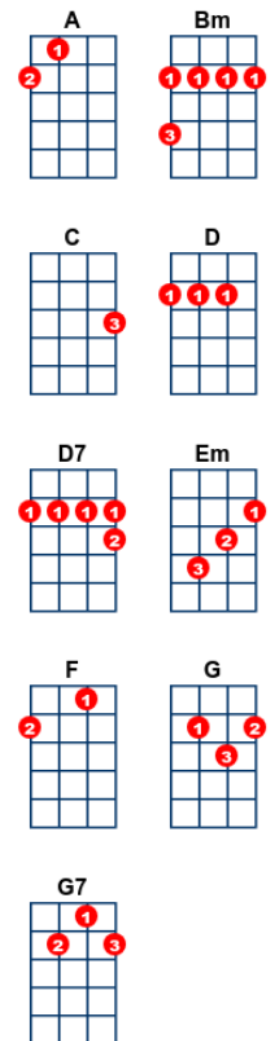

Cool For Cats

key:G, artist:Squeeze writer:Chris Difford & Glenn Tilbrook

Squeeze - https://www.youtube.com/watch?v=1JAK_UZ7xF8

[G] [Em] [C] [Am]

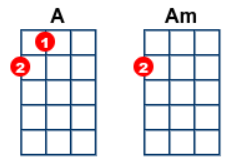

The **[G]** Indians send signals from the **[Em]** rocks above the pass
The **[C]** cowboys take positions in the **[Am]** bushes and the grass
The **[Eb]** squaw is with the Corporal she is **[Cm]** tied against the tree

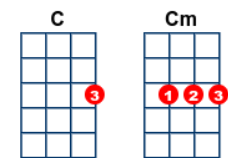

She **[Eb]** doesn't mind the language it's the **[Cm]** beating she don't need

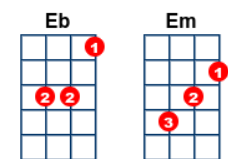

She **[Eb]** lets loose all the horses when the **[Cm]** Corporal is asleep

And he **[G]** wakes to find the fire's dead and **[Em]** arrows in his hats

And **[C]** Davy Crockett rides around and **[F]** says it's cool for cats
It's cool for **[Em]** cats (cool for **[A]** cats)

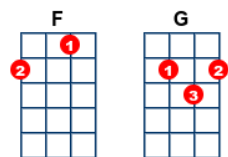

The **[G]** Sweeney's doing ninety cos they've **[Em]** got the word to go

They **[C]** get a gang of villains in a **[Am]** shed up at Heathrow
They're **[Eb]** counting out the fivers when the **[Cm]** handcuffs lock again
[Eb] In and out of Wandsworth with the **[Cm]** numbers on their names
It's **[Eb]** funny how their missus' always **[Cm]** look the bleeding same
And **[G]** meanwhile at the station there's a **[Em]** couple of likely lads
Who **[C]** swear like how's your father and they're **[F]** very cool for cats
They're cool for **[Em]** cats - cool for **[A]** cats

[Em] [A]

To **[G]** change the mood a little I've been **[Em]** posing down the pub
On **[C]** seeing my reflection I'm **[Am]** looking slightly rough
I **[Eb]** fancy this, I fancy that, I **[Cm]** wanna be so flash
I **[Eb]** give a little muscle and I **[Cm]** spend a little cash
But **[Eb]** all I get is bitter and a **[Cm]** nasty little rash
And **[G]** by the time I'm sober I've for-**[Em]**-gotten what I've had
And **[C]** ev'rybody tells me that it's **[F]** cool to be a cat
Cool for **[Em]** cats - cool for **[A]** cats

[G] Shake up at the disco and I **[Em]** think I've got a pull
I **[C]** ask her lots of questions and she **[Am]** hangs on to the wall
I **[Eb]** kiss her for the first time and **[Cm]** then I take her home
I'm in-**[Eb]**-vited in for coffee and I **[Cm]** give the dog a bone
She **[Eb]** likes to go to discos but she's **[Cm]** never on her own
I **[G]** said I'll see you later and I **[Em]** give her some old chat

But **[C]** it's not like that on the TV **[F]** when it's cool for cats
It's cool for **[Em]** cats - cool for **[A]*** cats **[Em]** **[A]** **[G]**

Dancing in the Dark

by: Bruce Springsteen Key [G]

(intro) [G] [Em] [G] [Em]

[G] I get up in the [Em] evening, and I [G] aint got [Em] nothing to [G] say

I come home in the [Em] morning,

[G] I go to bed [Em] feeling the same [C] way

I ain't nothing but [Am] tired,

[C] Man I'm just [Am] tired and bored with my-[G]self

Hey there [Em] baby, [G] I could [Em] use just a little [D] help

[D] You can't start a fire, you can't start a [G] fire without a [C] spark

This gun's for [Am] hire,

[C] even if we're just [Am] dancing in the [G] dark [Em]

[G] [Em]

[G] Messages keep getting [Em] clearer, [G] radio's on

and I'm [Em] moving around the [G] place

I check my look in the [Em] mirror, [G] wanna change my [Em] clothes my hair my [C] face

Man I ain't getting [Am] nowhere, [C] I'm just [Am] living in a dump like [G] this

There's something happening [Em] somewhere, [G] baby [Em] I just know that there [D] is

[D] You can't start a fire, you can't start a [G] fire without a [C] spark

This gun's for [Am] hire,

[C] even if we're just [Am] dancing in the [G] dark [Em]

[G] [Em]

[Em] You sit around getting [G] older

[C] There's a joke here [D] somewhere and it's on [Em] me

I'll shake the world off my [G] shoulders [C] Come on baby the [D] laughs on me

[G] Stay on the streets of [Em] this town, [G] and they'll be [Em] carving you up al [G] right

They say you gotta stay [Em] hungry, [G] Hey baby, I'm [Em] just about starving to [C] night

I'm dying for [Am] action, [C] sick of sitting round [Am] here trying to write this [G] book

I need a love re [Em] action, [G] Come on [Em] baby give me just one [D] look

[D] You can't start a fire, sitting round [G] crying on a broken [C] heart

This gun's for [Am] hire, [C] even if we're just [Am] dancing in the [G] dark

[D] You can't start a fire, worrying about your little world falling a [C] part

This gun's for [Am] hire, [C] even if we're just [Am] dancing in the [G] dark [Em]

[G] Even if we're just [Em] dancing in the [G] dark [Em] x4

[G] Hey baby!

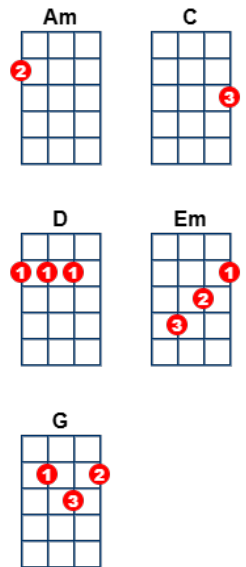

Don't Think Twice [C]

key:C, artist:Bob Dylan writer:Bob Dylan

Bob Dylan: <https://www.youtube.com/watch?v=u-Y3KfJs6T0> (in E)

Intro: [C] vamp till ready

[C] It ain't no use to [G] sit and wonder [Am] why, babe
[F] It don't matter, any[C]how. [G]
[C] And it ain't no use to [G] sit and wonder [Am] why, babe
[D7] If you don't know by [G] now. [G7]
[C] When your rooster crows at the [C7] break of dawn
[F] Look out your window and [D7] I'll be gone
[C] You're the [G] reason I'm [Am] trav'lin' [F] on
[C] Don't think [G] twice, it's all [C] right. [G]

[C] It ain't no use in [G] turnin' on your [Am] light, babe
[F] A light I never [C] knowed [G]
[C] An' it ain't no use in [G] turnin' on your [Am] light, babe
[D7] I'm on the dark side of the [G] road [G7]
[C] But I wish there was somethin' you would [C7] do or say
[F] To try and make me change my [D7] mind and stay
[C] We never [G] did too much [Am] talkin' any[F] way
[C] So don't think [G] twice, its all [C] right. [G]

[C] So it ain't no use in [G] callin' out my [Am] name, gal
[F] Like you never did be[C]fore [G]
[C] It ain't no use in [G] callin' out my [Am] name, gal
[D7] I can't hear you any[G] more [G7]
[C] I'm a-thinkin' and a-wond'rin' walking [C7] down the road
[F] I once loved a woman, a [D7] child I'm told
[C] I gave her my [G] heart but she [Am] wanted my [F] soul
[C] But don't think [G] twice, it's all [C] right [A] (key change)

[D] So long [A] honey [Bm] babe
[G] Where I'm bound, I can't [A] tell
[D] But goodbye is [A] too good a [Bm] word, gal
[E7] So I'll just say fare thee [A] well [A7]
[D] I ain't sayin' you treated [D7] me unkind
[G] You could have done better but [E7] I don't mind
[D] You just [A] kinda wasted [Bm] my precious [G] time
[D] Don't think [A] twice, it's all [D] right
[D] Don't think [A] twice, it's all [D] right [A]
[D] Don't think [A] twice, it's all [G] right [D]

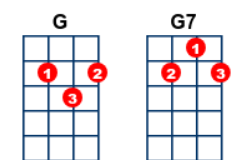
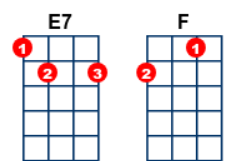
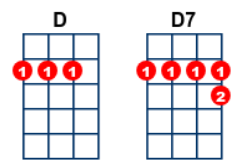
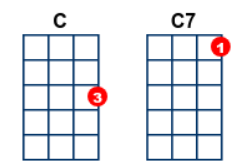
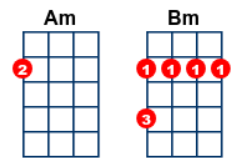
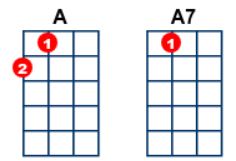

Don't Stop Believing - Journey

Intro: [C] [G] [Am] [F]

[C] Just a small [G] town girl [Am] livin' in a [F] lonely world
[C] She took the [G] midnight train goin' [Em] any [F] where

[C] Just a [G] city boy [Am] Born and raised in [F] South Detroit
[C] He took the [G] midnight train goin' [Em] any [F] where

[C] [G] [Am] [F]

[C] A singer in a [G] smokey room, [Am] the smell of wine and [F] cheap perfume
[C] For a smile they can [G] share the night
It goes [Em] on and on and [F] on and on

[F] Strangers waiting [C] Up and down the boulevard
Their [F] shadows searching In the [C] night
[F] Street-lights, People [C] Livin' just to find emotion.
[F] Hidin' somewhere in the [G] night [C] [G] / / / / [C] / / / [F] /

[C] [G] [Am] [F]

[C] Workin' hard to [G] get my fill, [Am] Everybody [F] wants a thrill
[C] Payin' anything to [G] roll the dice just [Em] one more [F] time

[C] Some will win, [G] some will lose, [Am] some were born to [F] sing the blues
[C] Oh, the movie [G] never ends

[F] Strangers waiting [C] Up and down the boulevard
Their [F] shadows searching In the [C] night
[F] Street-lights, People [C] Livin' just to find emotion.
[F] Hidin' somewhere in the [G] night [C] [G] / / / / [C] / / / [F] /

[C] [G] [Am] [F]

Chorus: * 3

[C] Don't stop be- [G] lievins',
[Am] hold on to that [F] feelin'
[C] Streetlights, [G] People... [Em] oh [F]

[C] Don't [C] stop!

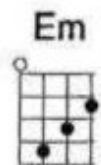
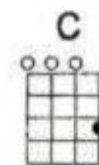
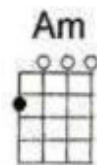

Doo Wah Diddy

key:C, artist:Manfred Mann writer:Jeff Barry and Ellie Greenwich

Manfred Mann: <https://www.youtube.com/watch?v=KFDmst7ULGI> capo 4

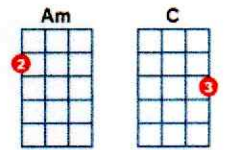

Intro: [C] [F] [C]

[NC] There she was just a walkin' down the street
Singin' [C] doo wah diddy diddy [F] dum diddy [C] doo
[C] Snappin' her fingers and [F] shufflin' her [C] feet
Singin' [C] doo wah diddy diddy [F] dum diddy [C] doo

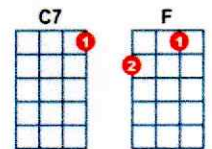

[C] She looked good (looked good) she looked fine (looked fine)
[C] She looked good she looked fine and I nearly lost my mind

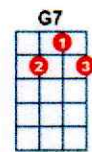

Be[C] fore I knew it she was [F] walkin' next to [C] me
Singin' [C] doo wah diddy diddy [F] dum diddy [C] doo
[C] Holdin' my hand just as [F] natural as can [C] be
Singin' [C] doo wah diddy diddy [F] dum diddy [C] doo

[C] We walked on (walked on) to my door (my door)
[C] We walked on to my door then we kissed a little more
[C] Whoa [C7] whoa I [Am] knew we was falling in love
[F] . yes I did and so I [G7] told her all the things I'd been dreamin' of

Now [C] we're together nearly [F] every single [C] day
Singin' [C] doo wah diddy diddy [F] dum diddy [C] doo
Oh [C] we're so happy and that's [F] how we're gonna [C] stay
Singin' [C] doo wah diddy diddy [F] dum diddy [C] doo

[C] I'm hers (I'm hers) she's mine (she's mine)
[C] I'm hers she's mine wedding bells are gonna chime
[C] Whoa [C7] whoa I [Am] knew we was falling in love
[F] . yes I did and so I [G7] told her all the things I'd been dreamin' of

[NC] Now we're together nearly every single day
Singin' [C] doo wah diddy diddy [F] dum diddy [C] doo
Oh [C] we're so happy and that's [F] how we're gonna [C] stay
Singin' [C] doo wah diddy diddy [F] dum diddy [C] doo

[C] I'm hers (I'm hers) she's mine (she's mine)
[C] I'm hers she's mine wedding bells are gonna chime [G7] whoa oh yeah
[C] Doo wah diddy diddy [F] dum diddy [C] doo x 3

Duelling Ukes - David Westwood

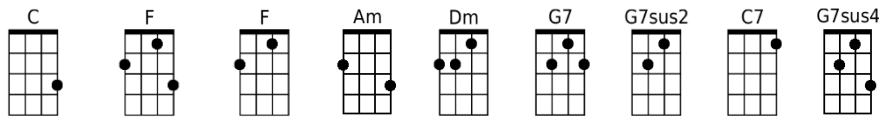

[X] = slap

Ukes: [C] [F/C] [C] [X] *single downstrokes only*

Banjoleles: [C] [F/C] [C] [X] *single downstrokes only*

Ukes: [C] [C] [F/C] [F/C] [C] [C] [C] [X] *single downstrokes only*

Banjoleles: [C] [C] [F/C] [F/C] [C] [C] [C] [X] *single downstrokes only*

Ukes: [C] [Am/C] [C] [Am/C] [C] [Am/C] [C] [X] *down and upstrokes per chord except final C*

Banjoleles: [C] [Am/C] [C] [Am/C] [C] [Am/C] [C] [X] *down and upstrokes per chord except final C*

Ukes: [F] [Dm] [F] [Dm] [F] [Dm] [F] [X] *down and upstrokes per chord except final F*

Banjoleles: [F] [Dm] [F] [Dm] [F] [Dm] [F] [X] *down and upstrokes per chord except final F*

Together: [G7] [G7sus2] [G7] [G7sus2] [G7] [G7sus2] [G7] [G7sus2]

[C] [Am/C] [C] [Am/C] [C] [Am/C] [C] [X] [X] *rolling strum*

Ukes: [C] [C7] [F] [X] *single downstrokes only*

Banjoleles: [C] [C7] [F] [X] *single downstrokes only*

Ukes: [C] [C] [C7] [C7] [F] [F] [F] [X] *single downstrokes only*

Banjoleles: [C] [C] [C7] [C7] [F] [F] [F] [X] *single downstrokes only*

Ukes: [G7] [G7sus4] [G7] [G7sus4] [G7] [G7sus4] [G7] [X] *down and upstrokes per chord except final G7*

Banjoleles: [G7] [G7sus4] [G7] [G7sus4] [G7] [G7sus4] [G7] [X] *down and upstrokes per chord except final G7*

Together: [C] [Am/C] [C] [Am/C] [C] [Am/C] [C] [X] [X] *rolling strum*

ALL: [C] [F/C] [C] [X] *single downstrokes only*

[C] [F/C] [C] [X] *single downstrokes only*

[C] [C] [F/C] [F/C] [C] [C] [C] [X] *single downstrokes only*

[C] [C] [F/C] [F/C] [C] [C] [C] [X] *single downstrokes only*

[C] [Am/C] [C] [Am/C] [C] [Am/C] [C] [X] *down and upstrokes per chord except final C*

[C] [Am/C] [C] [Am/C] [C] [Am/C] [C] [X] *down and upstrokes per chord except final C*

[F] [Dm] [F] [Dm] [F] [Dm] [F] [X] *down and upstrokes per chord except final F*

[F] [Dm] [F] [Dm] [F] [Dm] [F] [X] *down and upstrokes per chord except final F*

[G7] [G7sus2] [G7] [G7sus2] [G7] [G7sus2] [G7] [G7sus2]

[C] [Am/C] [C] [Am/C] [C] [Am/C] [C] [X] [X] *rolling strum*

FAT BOTTOMED GIRLS

[A/] ARE YOU GONNA [G/] TAKE ME HOME TO-[D/]-NIGHT ?
[A/] AH, DOWN BE-[G/]-SIDE THAT RED FIRE [E7/] LIGHT
[A/] ARE YOU GONNA [D/] LET IT ALL HANG OUT ?
FAT BOTTOMED [A/] GIRLS
YOU MAKE THE [E7/] ROCKIN' WORLD GO [A] ROUND

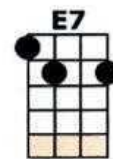

HEY I WAS [A] JUST A SKINNY LAD
NEVER KNEW NO GOOD FROM BAD
BUT I KNEW LIFE BEFORE I LEFT MY NURSER-[E7]-Y
LEFT A-[A]-LONE WITH BIG FAT FANNY
SHE WAS [D] SUCH A NAUGHTY NANNY
HEAP BIG [A] WOMAN - YOU MADE A [E7] BAD BOY OUT OF [A] ME

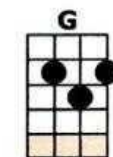

I'VE BEEN [A] SINGING WITH MY BAND
ACROSS THE WATER, ACROSS THE LAND
I'VE SEEN EVERY BLUE EYED FLOOZY ON THE [E7] WAY
BUT THEIR [A] BEAUTY AND THEIR STYLE
WENT KIND OF [D] SMOOTH AFTER A WHILE
TAKE ME [A] TO THEM NAUGHTY [E7] LADIES EVERY [A] TIME

CHORUS:

[A] OH, WON'T YOU [G] TAKE ME HOME TO-[D]-NIGHT ?
[A] OH, DOWN BE-[G]-SIDE YOUR RED FIRE [E7] LIGHT
[A] OH, AND YOU [D] GIVE IT ALL YOU GOT
FAT BOTTOMED [A] GIRLS
YOU MAKE THE [E7] ROCKIN' WORLD GO [A] ROUND [D]
FAT BOTTOMED [A] GIRLS
YOU MAKE THE [E7] ROCKIN' WORLD GO [A] ROUND

NOW I GOT [A] MORTGAGES ON HOMES
AND I GOT STIFFNESS IN THE BONES
AIN'T NO BEAUTY QUEENS IN THIS LOCALI-[E7]-TY
OH BUT [A/] I STILL GET MY PLEASURE
[A/] STILL [D/] GOT MY GREATEST TREASURE
[D] HEAP BIG [A/] WOMAN YOU GONE AND MADE A
[E7/] BIG MAN OUT OF [A] ME

CHORUS

FAT BOTTOMED [A] GIRLS
YOU MAKE THE [E7] ROCKIN' WORLD GO [A] ROUND [D]
FAT BOTTOMED [A] GIRLS
YOU MAKE THE [E7] ROCKIN' WORLD GO [A] ROUND

I Can't Find My Way Home (key:D) Artist: Blind Faith (Ukulele)

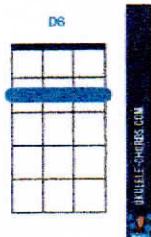
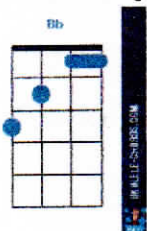

[Mandolin:]

[C] [G] [Bb] [D] [F] [G] [D]

[C] [G] [Bb] [D] [F] [G] [D]

[Ukes + mandolin:]

[D] Come [C] down off your [G] throne, and [Bb] leave your body a-[D]lone.

[F] Some-[G]body must [D] change.

[C] You are the [G] reason, I've been [Bb] waiting so [D] long.

[F] Some-[G]body hold's the [D] key.

[D] Well I'm, [G] near the end and I, [A] just ain't got the [D] time. Oh, Oh [Em] Oh,
And I'm wasted and I, [G] can't find [D6] my way [D] home.

[Mandolin + Ukes + Harmonica:]

[C] [G] [Bb] [D] [F] [G] [D]

[C] [G] [Bb] [D] [F] [G] [D]

Come [C] down on your [G] own, and [Bb] leave your body a-[D]lone.

[F] Some-[G]body must [D] change.

[C] You are the [G] reason, I've been [Bb] waiting all these [D] years

[F] Some-[G]body holds the [D] key.

Well I'm, [G] near the end and I, [A] just ain't got the [D] time. Oh, Oh, [Em] Oh
And I'm wasted and I, [G] can't find [D6] my way [D] home.

[Ukes + Mandolin lead]

[C] [G] [Bb] [D] No, I [F] can't find [G] my way [D] home.

[C] [G] [Bb] [D] But, I [F] can't find [G] my way [D] home.

[C] [G] [Bb] [D] No, I [F] can't find [G] my way [D] home.

[C] [G] [Bb] [D] Well I [F] can't find [G] my way [D] home.

[C] [G] [Bb] [D] But I [F] can't find [G] my way [D] home.

[C] [G] [Bb] [D] [slowing] Still I [F] can't find [G]..... my way..... [D] home.

Maybe Tomorrow

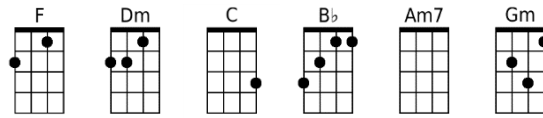

INTRO [F] 4 bars

[NC] There's a [Dm] voice that keeps on calling [C] me
Down the [Dm] road. That's where I'll always [C] be
Every [F] stop I make, I make a new [Dm] friend
Can't stay for [Bb] long. Just turn a [C] round, and I'm gone a [F] gain

Chorus

[NC] Maybe to [Dm]morrow, I'll [Bb] want to settle [F] down [Am7] [Dm]
Until to [Gm]morrow, I'll [Bb] just keep moving [F] on

Down this [Dm] road, that never seems to [C] end
Where new ad[Dm]venture lies just around the [C] bend
So if you [F] want to join me for a [Dm] while
Just grab your [Bb] hat, we'll travel [C] light, that's hobo [F] style

[NC] Maybe to [Dm]morrow, I'll [Bb] want to settle [F] down [Am7] [Dm]
Until to [Gm]morrow, the [Bb] whole world is my [F] home

There's a [Dm] world that's waiting to un[C]fold
A brand-new [Dm] tale, no-one has ever [C] told
We've journeyed [F] far, but you know it won't be [Dm] long
We're almost [Bb] there and we've paid our [C] fare with the hobo [F] song

Instrumental

[NC] There's a [Dm] world that's waiting to un[C]fold
A brand-new [Dm] tale, no-one has ever [C] told
We've journeyed [F] far but you know it won't be [Dm] long
We're almost [Bb] there and we've paid our [C] fare with the hobo [F] song

[NC] Maybe to [Dm]morrow, I'll [Bb] find what I call [F] home [Am7] [Dm]
Until to [Gm]morrow, you [Bb] know I'm free to [F] roam.

So if you [F] want to join me for a [Dm] while,
Just grab your [Bb] hat, we'll travel [C] light, that's hobo [F] style.

[NC] Maybe to [Dm]morrow, I'll [Bb] want to settle [F] down [Am7] [Dm]
Until to [Gm]morrow, I'll [Bb] just keep moving [F] on
Until to [Gm]morrow, the [Bb] whole world is my [F] home.

Me and Julio Down by the Schoolyard

key:G, artist:Paul Simon, writer:Paul Simon

Intro : [G]-[C]-[G]-[D] x 2

The [G] mama Pyjama rolled out of bed and she ran to the police sta[C]tion
 When the [D] papa found out he began to shout and he started the investi-[G]gation
 It's against the [D] law, it was against the [G] law
 What the mama [D] saw, it was against the [G] law
 [G] Mama looked down and spit on the ground every time my name gets
 men[C]tioned
 And the [D] papa said, Oi, when I get that boy
 I'm gonna stick him in the house of de-[G]tention (pause)

Well I'm on my [C] way, I don't know [G] where I'm goin'
 I'm on my [C] way, takin' my [G] time but I [A] don't know [D] where
 Goodbye to [C] Rosie, the queen of Cor[G]ona
 Seein' [G] me and [F] Julio [C] down by the [D] schoolyard [G]-[C]-[G]-[D]
 Seein' [G] me and [F] Julio [C] down by the [D] schoolyard [G]-[C]-[G]-[D]
Well I'm on my [C] way, I don't know [G] where I'm goin'
I'm on my [C] way, takin' my [G] time but I [A] don't know [D] where
Goodbye to [C] Rosie, the queen of Cor[G]ona
Seein' [G] me and [F] Julio [C] down by the [D] schoolyard [G]-[C]-[G]-[D]
Seein' [G] me and [F] Julio [C] down by the [D] schoolyard [G]-[C]-[G]-[D]
[D] (multiple strum then stop)

[NC] Whoa-oh
 In a [G] couple of days they're gonna take me away
 But the press let the story [C] leak
 And when the [D] radical priest comes to get me released
 We is all on the cover of [G] Newsweek (pause)
 Well I'm on my [C] way, I don't know [G] where I'm goin'
 I'm on my [C] way, takin' my [G] time but I [A] don't know [D] where
 Goodbye to [C] Rosie, the queen of Cor[G]ona
 Seein' [G] me and [F] Julio [C] down by the [D] schoolyard [G]-[C]-[G]-[D]
 Seein' [G] me and [F] Julio [C] down by the [D] schoolyard [G]-[C]-[G]-[D]
 Seein' [G] me and [F] Julio [C] down by the [D] schoolyard [G]-[C]-[G]-[D]
 Seein' [G] me and [F] Julio [C] down by the [D] schoolyard [G]-[C]-[G]-[D]
 [G]

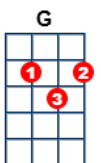
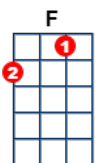
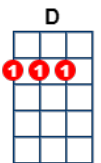
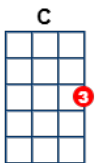
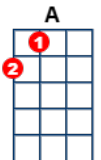

Mrs. Robinson - Simon & Garfunkel

writer:Paul Simon

[intro – similar to verse]

[E7] Dee dedee dee.... | **[A7]** | **[D]** **[G]** **[C-G-Am]** **[Am]** | **[E7]** **[D7]**

And here's to **[G]**you, Mrs **[Em]**Robinson... **[G]**Jesus loves you
[Em]more than you will **[C]**know... oh-oh **[D]**oh
God bless you **[G]**please Mrs **[Em]**Robinson... **[G]**Heaven holds a
[Em]place for those who **[C]**pray... hey hey **[Am]**hey Hey hey **[E7]**hey

[E7] We'd **[E7]**like to know a little bit about you for our files
We'd **[A7]**like to help you learn to help yourself
[D] Look around you **[G]**all you see are **[C]**sympa**[G]**thetic **[Am]**eyes
[E7] Stroll around the grounds un**[D7]**til you feel at home

And here's to **[G]**you, Mrs **[Em]**Robinson... **[G]**Jesus loves you
[Em]more than You will **[C]**know... oh-oh **[D]**oh
God bless you **[G]**please Mrs **[Em]**Robinson... **[G]**Heaven holds a
[Em]place for those who **[C]**pray... hey hey **[Am]**hey Hey hey **[E7]**hey

[E7] Hide it in a hiding place where no one ever goes
[A7] Put it in your pantry with your cupcakes
[D] It's a little **[G]**secret just the **[C]**Robin**[G]**sons' a**[Am]**ffair
[E7] Most of all you've got to **[D7]**hide it from the kids

Coo-coo-ca-**[G]**choo, Mrs **[Em]**Robinson... **[G]**Jesus loves you **[Em]**more than You will
[C]know... oh-oh **[D]**oh
God bless you **[G]**please Mrs **[Em]**Robinson... **[G]**Heaven holds a **[Em]**place for those
who **[C]**pray... hey hey **[Am]**hey Hey hey **[E7]**hey

[E7] Sitting on a sofa on a Sunday afternoon
[A7] Going to the candidates debate
[D] Laugh about it **[G]**shout about it **[C]**when you've **[G]**got to **[Am]**choose
[E7] Every way you look at it you **[D7]**lose

Where have you **[G]**gone Joe Di**[Em]**Maggio? Our **[G]**nation turns its **[Em]**lonely eyes to
[C]You... ooh-ooh **[D]**ooh
What's that you **[G]**say, Mrs **[Em]**Robinson? **[G]**Joltin's Joe has **[Em]**left and gone
A**[C]**way... hey hey **[Am]**hey Hey hey **[E7]**hey

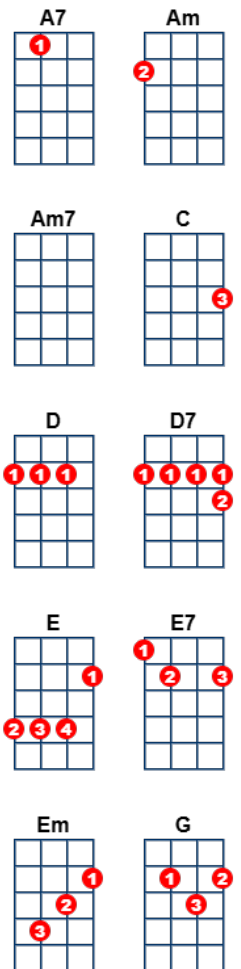

Oom Pah Pah

key:C, artist:Oliver Stage Show writer:Lionel Bart

https://www.youtube.com/watch?v=OIKccuS_ayk Capo on 2

Intro: 2 Bars on **[C]**

[C] There's a little ditty they're **[D7]** singin' in the city
[G7] Especially when they've been on the **[D7]** gin or the **[G7]**
beer

[C] If you've got the patience your **[D7]** own imaginations'll
[G7] Tell you just exactly what **[C]** you want **[C]** to **[C]** hear

[C] Oom-pah-pah, oom-pah-pah, **[D7]** that's how it goes
[G7] Oom-pah-pah, oom-pah-pah, **[C]** ev'ryone **[G7]** knows
[C] They all suppose what they **[D7]** want to suppose
[G7] When they hear oom-pah **[C]** pah 2 3, 1 2 3

[C] Mister Percy Snodgrass would **[D7]** often have the odd glass
But **[G7]** never when he thought any**[D7]**body could **[G7]** see
[C] Secretly he'd buy it and **[D7]** drink it on the quiet
And **[G7]** dream he was an Earl with a **[C]** girl on **[C]** each **[C]**knee

[C] Oom-pah-pah, oom-pah-pah, **[D7]** that's how it goes
[G7] Oom-pah-pah, oom-pah-pah, **[C]** ev'ryone **[G7]** knows
[C] What is the cause of his **[D7]** red shiny nose
[G7] Could it be oom-pah **[C]** pah 2 3, 1 2 3

[C] Pretty little Sally goes **[D7]** walkin' down the alley
Dis**[G7]** plays a pretty ankle to **[D7]** all of the **[G7]** men
[C] They could see her garters, but **[D7]** not for free and gratis
An **[G7]** inch or two and then she knows **[C]** when to **[C]** say **[C]** when

[C] Oom-pah-pah, oom-pah-pah, **[D7]** that's how it goes
[G7] Oom-pah-pah, oom-pah-pah, **[C]** ev'ryone **[G7]** knows
[C] Whether it's hidden, or **[D7]** whether it shows
[G7] It's the same, oom-pah **[C]** pah 2 3, 1 2 3

[C] Oom-pah-pah, oom-pah-pah, **[D7]** that's how it goes
[G7] Oom-pah-pah, oom-pah-pah, **[C]** ev'ryone **[G7]** knows
[C] Whether it's hidden, or **[D7]** whether it shows
[G7] It's the same, oom-pah **[C]** pah 2 3 **[C]**

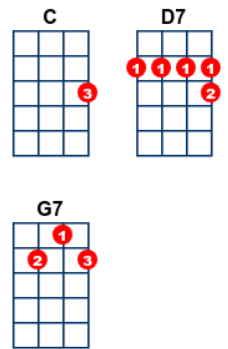

Pretty Flamingo. Manfred Mann

Intro: [G] [C] [G] [C] [G] [C] [G]

[C] On our [G] block [C] all of the [G] guys [C] call her fla[G]mingo

[C] Cause her [D7] hair glows [G] like the sun

[C] And her [D7] eyes can [G] light the [C] sky

[C] When she [G] walks [C] she moves so [G] fine

[C] Like a fla[G]mingo

[C] Crimson [D7] dress that [G] clings so tight

She's [C] out of [D7] reach and [G] out of [C] sight [G]

When [G7] she walks [C] by

She [D7] brightens up the [G] neighbourhood [G7]

Oh every [C] guy would [D7] make her his

If [G] he just could, if [D7] she just would [D7]

Some sweet [G] day [C] I'll make her [G] mine [C] pretty fla[G]mingo

Then [C] every [D7] guy will [G] envy me

Cause [C] para[D7]dise is [G] where I'll [C] be [G]

Solo (first line of verse repeated): [G] [C] [G] [C] [G] [G] [C] [G] [C] [G] X 2

When [G7] she walks [C] by

She [D7] brightens up the [G] neighbourhood [G7]

Oh every [C] guy would [D7] make her his

If [G] he just could, if [D7] she just would [D7]

Some sweet [G] day [C] I'll make her [G] mine [C] pretty fla[G]mingo

Then [C] every [D7] guy will [G] envy me

Cause [C] para[D7]dise is [G] where I'll [C] be [G]

[G] Sha la la [C] la la la [G] la [C] pretty fla[G]mingo (someday I will make her mine)

[G] Sha la la [C] la la la [G] la [C] pretty fla[G]mingo (oh yes I will, I'll make her mine)

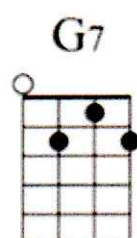
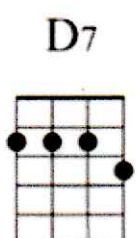
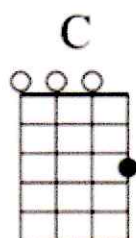
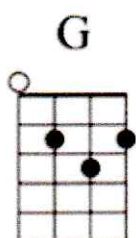

River Deep Mountain High

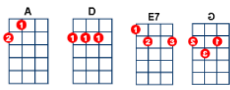

When I was a little **[D]** girl I had a rag doll
Only doll I've ever **[A]** owned
Now I love you just the **[D]** way I loved that rag doll
But only now my love has **[A]** grown
And it gets **[E7]** stronger in every **[A]** way
And it gets **[E7]** deeper let me **[A]** say
And it gets **[E7]** higher day by **[A]** day

And **[G]** do I love you my oh my
Yeah **[A]** river deep mountain high
[G] If I lost you would I cry
[A] Oh how I love you baby baby baby baby

When you were a young boy
[D] did you have a puppy
That always followed you **[A]** around
Well I'm gonna be as **[D]** faithful as that puppy
No I'll never let you **[A]** down
Cause it goes **[E7]** on and on like a river **[A]** flows
And it gets **[E7]** bigger baby and heaven **[A]** knows
And it gets **[E7]** sweeter baby as it **[A]** grows

And **[G]** do I love you my oh my
Yeah **[A]** river deep mountain high
[G] If I lost you would I cry
[A] Oh how I love you baby baby baby baby

[A] I love you baby like a flower loves the spring
[A] And I love you baby just like a robin loves to sing
[D] And I love you baby like a school boy loves his pie
[A] And I love you baby river deep mountain high

12 bars **[A]** with Baby Oooohhhh etc

And **[G]** do I love you my oh my
Yeah **[A]** river deep mountain high

[G] If I lost you would I cry
[A] Oh how I love you baby baby baby baby

Senses Working Overtime XTC

From: Richard G's Ukulele Songbook www.scorpexuke.com

Intro: [Em] [D] [Em] [D] [Em] [D] [Em] [D] [Em]

Hey [D] hey the [Em] clouds are [D] whey

There's [Em] straw for the [D] donkeys

And the [Em] innocents can [D] all sleep [Amadd9] safe[Am]ly [Amadd9]

[Am] All sleep [Amadd9] safe[Am]ly [Amadd9] [Am]

[Em] My [D] my [Em] sun is [D] pie there's [Em] fodder for the [D] cannons

And the [Em] guilty ones can [D] all sleep [Amadd9] safe[Am]ly [Amadd9]

[Am] All sleep [Amadd9] safe[Am]ly [Amadd9] [Am]

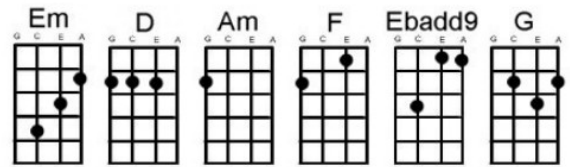

Pre-Chorus: [F] And all the [Ebadd9] world is (1) *football* / (2) *biscuit* [F] shaped

It's just for [Ebadd9] me to kick in [G] (1) *space* / (2) *feed my face*

[G] And I can [Fadd9] see hear smell touch [G] taste

Chorus:

[G] And I've got [C]12[G]34[C]5 (*tap*) senses working [F] o[C]ver[G]time

[F] Trying to [G] take this [C] all in

I've got [C]12[G]34[C]5 (*tap*) senses working [F] o[C]ver[G]time

[F] Trying to taste the [G] difference between a [F] lemon and a [G] lime

[F] Pain and [G] pleasure and the [C] church bells softly chime ...

[Em] [D] [Em] [D] [Em] [D] [Em] [D] [Em]

Hey [D] hey [Em] night fights [D] day there's [Em] food for the [D] thinkers

And the [Em] innocents can [D] all live [Amadd9] slow[Am]ly [Amadd9]

[Am] All live [Amadd9] slow[Am]ly [Amadd9] [Am]

[Em] My [D] my the [Em] sky will [D] cry [Em] jewels for the [D] thirsty

And the [Em] guilty ones can [D] all die [Amadd9] slow[Am]ly [Amadd9]

[Am] All die [Amadd9] slow[Am]ly [Amadd9] [Am]

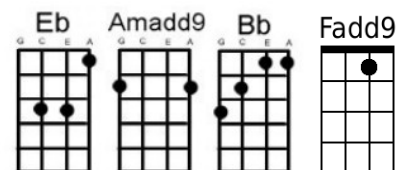

Pre-Chorus 2

Repeat Chorus

[F] [Eb] [F] [Eb] [F] [Eb] [F] [Eb]

[F] And [Eb] birds might [F] fall from [Eb] black skies [F] [Eb] [F] [Eb]

[F] And [Eb] bullies might [F] give you [Eb] black eyes [F] [Eb] [F] [Eb]

[F] But to [Eb] me they're [F] very [Eb] very [Bb] bea[F]uti[Bb]fu[F]l

[Bb] [F] [Bb] [F] [Bb] Bea[F]uti[Bb]fu[F]l [Eb] [D]

Repeat Pre-Chorus 2

Repeat Chorus

Sam Hall

key:C, artist:Johnny Cash writer:Traditional

<https://www.youtube.com/watch?v=SD5HIFbPrgw>

[C]

[C] Well my name it is Sam Hall, Sam Hall

Yes my name it is Sam Hall, it is Sam [G7] Hall

My [C] name it is Sam [C7] Hall, and I [F] hate you one and all

And I [C] hate you one and [G7] all, damn your [C] eyes.

[C] I killed a man they said, so they said

I killed a man they said, so they [G7] said

I [C] killed a man they [C7] said, and I [F] smashed in his [Fm] head

And I [C] left him layin' [G7] dead, damn his [C] eyes.

[C] Well a-swingin I must go, I must go

A-swingin I must go, I must [G7] go

A-[C]swingin I must [C7] go, while you [F] critters down be-[Fm]low

Yell out [C] "Sam I told you [G7] so", well damn your [C] eyes.

[C] Well my name it is Sam Hall, Sam Hall

[C] Yes my name it is Sam Hall, it is Sam [G7] Hall

[C] My [C] name it is Sam [C7] Hall, and I [F] hate you one and all

[C] And I [C] hate you one and [G7] all, damn your [C] eyes.

[C] I saw Molly in the crowd, in the crowd

I saw Molly in the crowd, in the [G7] crowd

I saw [C] Molly in the [C7] crowd, and I [F] hollered right out [Fm] loud

Hey there [C] Molly ain't you [G7] proud, damn your [C] eyes.

[C] Then the Sheriff he came too, he came too

Aw yeah, the Sheriff he came too, he came [G7] too

The [C] Sheriff he come [C7] too, [F] and he said "Sam how are [Fm] you?"

And I said "[C] Well Sheriff how are [G7] you? Damn your [C] eyes."

[C] My name is Samuel, Samuel

My name is Samuel, Samu-[G7]el

My [C] name is Samu-[C7]el, and I'll [F] see you all in [Fm] hell

And I'll [C] see you all in [G7] hell, damn your [C] eyes.

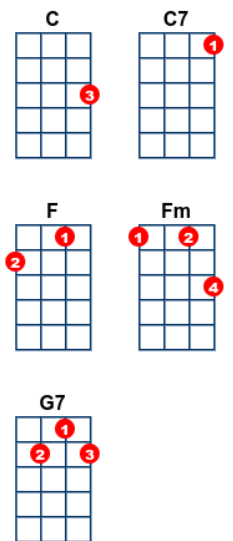

We will Rock You

1st verse

[Em]Buddy you're a boy make a [Em] big noise
Playing in the [Em] street gonna be a big [A] man some [G] day
You got [Em] mud on your face, you [Em] big disgrace
[D] Kickin' your can all [A] over the place, Singin'

Chorus

[G] We [D] will, [Em] we [D] will [Em] rock you
[G] We [D] will, [Em] we [D] will [Em] rock you

2nd verse

[Em] Buddy you're a young man [Em] hard man
Shouting in the [Em] street gonna take on the [A] world some [G] day
You got [Em] blood on your face, you [Em] big disgrace
[D] Wavin' your banner all [A] over the place

Chorus

[G] We [D] will, [Em] we [D] will [Em] rock you, [Em] singin' !
[G] We [D] will, [Em] we [D] will [Em] rock you

3rd verse

[Em] Buddy you're an old man [Em] poor man
Pleading with your [Em] eyes gonna make you some [A] peace some [G] day
You got [Em] mud on your face, [Em] big disgrace
Some[D]body better put you back [A] into your place

Chorus

[G] We [D] will, [Em] we [D] will [Em] rock you, [Em] singin' !
[G] We [D] will, [Em] we [D] will [Em] rock you everybody..
[G] We [D] will, [Em] we [D] will [Em] rock you
[G] We [D] will, [Em] we [D] will [Em...] rock you

^G Drink up thy zider, George, pass us round the jug,
^G drink up thy zider, George, thy garden's well nigh dug.
 There's dung all o'er thy tater's and half way up thy gater's
 and there's still more zider in the jug.

MEL'S
WURZELS MEDLEY

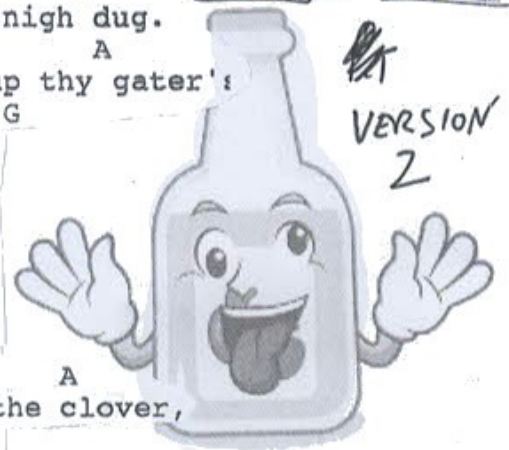

[Chorus]

^G Drink up thy zider, drink up thy zider,
^G for tonight we'll merry be.
^G We'll knock the milk ~~made~~ over and roll 'em in the clover,
^D the corns half cut and so ~~are~~ we.

An ever bigger pile of hits !!

^{D7} I drove my tractor through your haystack last night (ooh aah ooh aah)
^G I threw me pitchfork at your dog to keep quiet (ooh aah ooh aah)
 Now something's telling me, that you'm avoiding me
^C Come on now darling you've got something I need.

^G Cuz I got a brand new combine harvester an' I'll give you the key
^G Come on now let's get together in perfect harmony
^C I got twenty acres, an' you got forty-three
^D Cuz got a brand new combine harvester an' I'll give you the key

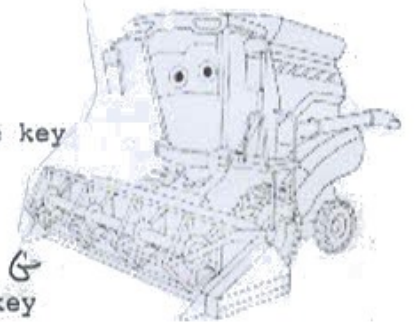

^G Well I've never been to school, never been
^D to college
 Sooner be dead that stuff me head with a
 load of useless knowledge
 I never couldn't see, no point in history
^D 'Cos I weren't there, so I don't care,
 So don't tell I, tell 'E!

Chorus
^D Don't tell I, tell 'E, that's my philosophy
^C When folks do swear, and tear their hair,
^G Don't tell I, tell 'E!

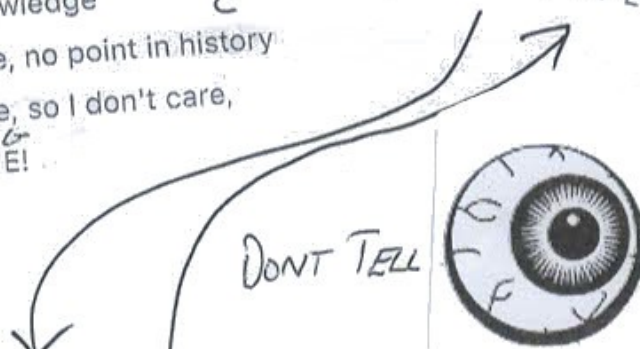

^G Now we got a lift to town, with good old Farmer Brown
^D On a ten ton truck, with a load o' muck, and when he set us down
^G A drink we did agree, it would be good for we,
^C The barmaid rose, she 'eld 'er nose, I said,
^G "Don't smell I, smell 'E!"

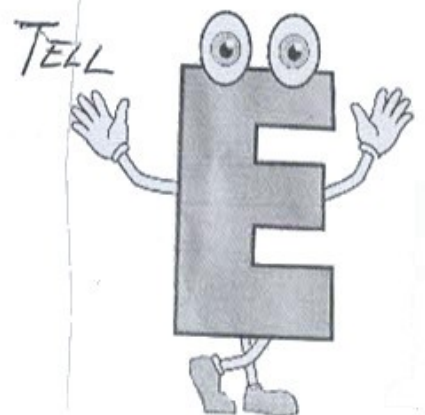

G C
 All my life I'm on the farm, working for me keep.
 D G
 Tending pigs and chickens, and them cows and sheep.
 C
 But everywhere I'm working, there's one who always mocks me.
 D G
 He's hiding somewhere in the trees, blackbird I'll 'ave he



G C D G
 Where be that Blackbird to? I know where he be.
 D G
 He be up yon Wurzel tree. And I be after he.
 G E C
 Now I sees he. He sees I. Biggered if I don't get ~~him~~.
 D G
 With a gert big stick I'll knock him down. Blackbird I'll 'ave he.
 D G
 La la la la la la. la la la la la la. Ow's your father? Alright.

(NOT Eminor)
 E'S A BLACKBIRD

G
 Hitch up the wagon, get out the grey mare,
 C G
 we ha'nt been drunk since Bridgwater fair.
 C G
 Get George and Jacko and Chloe and Joe,
 A D
 get everyone you know.



G C G
 Bring out your brother, your sister and dad, get everyone in sight.
 D7 G C G
 Oh we'll dance and shout, and roll about, all over Mendip tonight

G C G
 When the moon shines on the cow shed
 G C G
 and we're rollin in the hay
 G C G
 all the cows are out there grazing
 D G
 and the milk is on its way
 G C G
 It's so cosy in the kitchen
 G C G
 with the smell of rabbit stew
 G C G
 when the breeze blows cross the farmyard
 D G
 you can smell the cow sheds too
 G
 (oh I've never smelt nothing like it in all my life !)
 G /A C/D C/D G/A
 I am a cider drinker, I drinks it all of the day
 G /A C/D C/D G/A
 I am a cider drinker, it soothes all me troubles away
 G /A D/E D/E G/A
 oh arr oh arr aay, oh arr oh arr aay



} REPEAT IN
 HIGHER KEY